

# 2720 LARGO CHAIR

## Contents:

- (1) Seat, (1) Back
- (2) Arm Rests
- (2) Front Chair legs
- (2) Back Chair legs

- (2) 1/4 - 20 x 2 1/2" Bolts
- (8) 1/4 - 20 x 2 1/4" Bolts
- (6) 1/4 - 20 x 2" Bolts
- (12) Locknuts

## Tools Required:

- #3 Phillips Head Screwdriver
- 7/16" Wrench

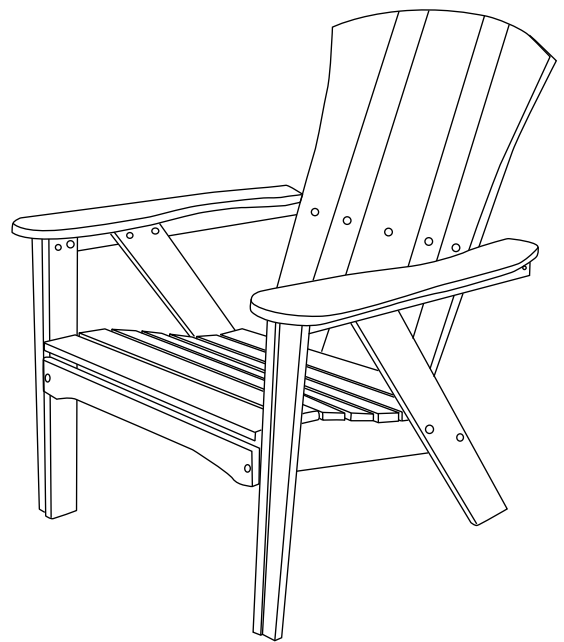
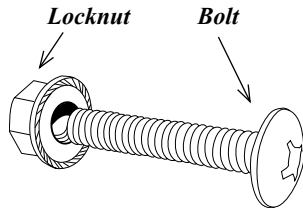

1.

a. Align predrilled holes then insert 2" bolts to attach front legs.

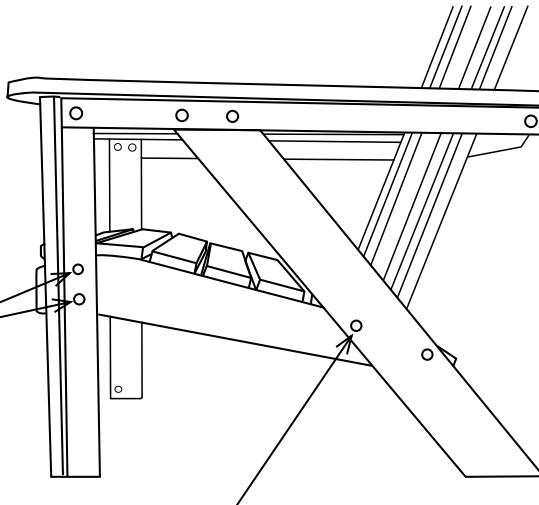

b. Align predrilled holes then insert 2" bolts to attach back legs.

2. Place arm rest on top of chair legs, align front predrilled holes, insert 2 1/4" bolts.

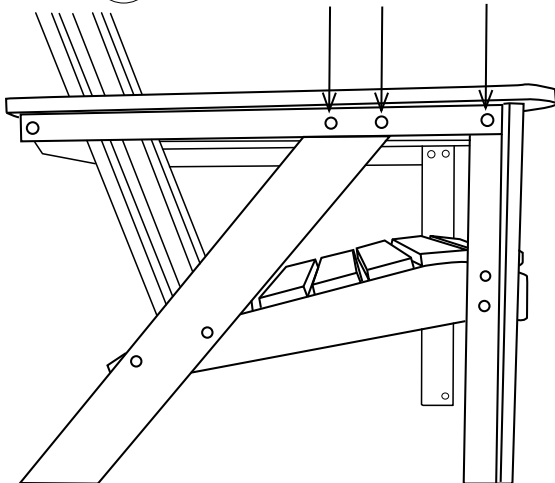

3.

3a. Attach the seat back to the arms by aligning the predrilled holes and inserting a 2 1/4" bolt.

3b. Attach the seat back to the bottom support by aligning the predrilled holes and inserting a 2 1/2" bolt.

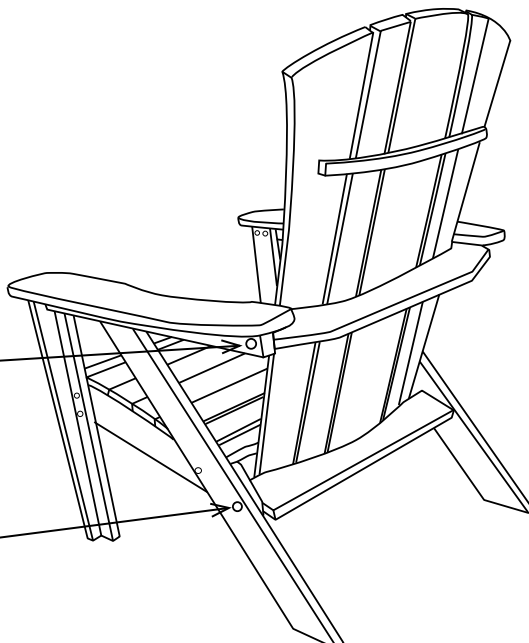

## Assembly Instructions

1. a. With the wing on the post facing front, align the predrilled holes on front leg to the seat and insert the 1/4 - 20 x 2" Bolts through the leg in thru the seat. Clean any plastic residue from the bolt then screw on the locknut and tighten it with the wrench and phillips screwdriver. Repeat on the other front leg.

b. Align the predrilled holes on the back leg to the seat and insert the 1/4 - 20 x 2" Bolts through the leg in thru the seat. Clean any plastic residue from the bolt then screw on the locknut and tighten it with the wrench and phillips screwdriver. Repeat on the other back leg.

2. Place arm rest on top of chair legs align the front predrilled holes and insert the 1/4 - 20 x 2 1/4" Bolts through the leg and in thru the arm. Clean off any plastic residue then screw on the locknut and tighten it with the wrench and phillips screwdriver.

3. a. Attach the back of the chair to the arm by aligning the predrilled holes on the armrest and seat back and inserting a 1/4 - 20 x 2 1/4" Bolt then tighten with a phillips screwdriver.

b. Attach the back of the chair to the leg by aligning the predrilled holes and inserting a 1/4 - 20 x 2 1/2" Bolt thru the back leg and into the chair back, bottom support then tighten with a phillips screwdriver. Repeat on other side.

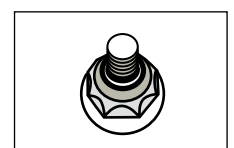

Properly seated locknut.



## **Care & Maintenance**

Ocean Comfort products are constructed from HDPE (High Density Polyethylene), primarily a recycled material. UV inhibitors are also added to resist fading. Simply maintain your furniture by cleaning with soap and warm water to ensure its long lasting beauty. A soft bristle brush can be used on any tough to clean stains. Stainless steel hardware is used in the assembly of these products and should be rinsed regularly with fresh water if being used in a coastal environment.

## **KETTLER Limited Warranty**

Ocean Comfort products are guaranteed for a period of 20 years (for residential use) and 5 years (for commercial use), starting from original purchase date. This warranty covers defects in materials and/or workmanship and does not apply to the hardware.

Warranty not applicable to any products deemed as misused, abused or damaged due to an uncontrollable act of nature.

\*For Parts and Service, please contact us directly at 866-804-0440 or email [parts@kettlerusa.com](mailto:parts@kettlerusa.com)



Made in the U.S.A.

KETTLER® International Inc. • 1355 London Bridge Road • Virginia Beach, VA 23453  
[www.kettlerusa.com](http://www.kettlerusa.com) • [info@kettlerusa.com](mailto:info@kettlerusa.com)